

IMPORTANT SAFETY INSTRUCTIONS

When using an electrical appliance, basic safety precautions should always be followed, including the following:
Read all instructions before using this appliance.

DANGER — To reduce the risk of electric shock:

1. An appliance should never be left unattended when plugged in. Always unplug this sewing machine from the electric outlet immediately after using and before cleaning.
2. Always unplug before replacing a sewing machine bulb. Replace bulb with same type rated 15 Watts.

WARNING — To reduce the risk of burns, fire, electric shock or injury to persons:

1. Do not allow this sewing machine to be used as a toy. Close attention is necessary when this sewing machine is used by or near children.
2. Use this appliance only for its intended use as described in this owner's manual. Use only attachments recommended by the manufacturer as contained in this owner's manual.
3. Never operate this sewing machine if it has a damaged cord or plug, if it is not working properly, if it has been dropped or damaged, or dropped into water.
Return this sewing machine to the nearest authorized dealer or service center for examination, repair, electrical or mechanical adjustment.
4. Never operate the appliance with any air opening blocked. Keep ventilation openings of this sewing machine and foot controller free from accumulation of lint, dust and loose cloth.
5. Never drop or insert any object into any opening.
6. Do not use outdoors.
7. Do not operate where aerosol (spray) products are being used or where oxygen is being administered.
8. To disconnect, turn all controls to the off ("O") position, then remove plug from outlet.
9. Do not unplug by pulling on cord. To unplug, grasp the plug, not the cord.
10. Keep fingers away from all moving parts. Special care is required around the sewing machine needle.
11. Always use the proper needle plate. The wrong plate can cause the needle to break.
12. Do not use bent needles.
13. Do not pull or push fabric while stitching. It may deflect the needle, causing it to break.
14. Switch this sewing machine off ("O") when making any adjustment in the needle area, such as threading the needle, changing the needle, threading the bobbin, changing the presser foot, and the like.
15. Always unplug this sewing machine from the electrical outlet when removing covers, lubricating, or when making any other adjustments mentioned in this owner's manual.

SAVE THESE INSTRUCTIONS

TABLE OF CONTENTS

SECTION I NAMES OF PARTS

Names of Parts	3
• How to attach the spool pin	3
Standard Accessories and Storage Place	4
• Free arm	4

SECTION II GETTING READY TO SEW

Connecting Machine to Power Supply	5
Controlling Sewing Speed	5
• Foot control	5
Operating Instructions	5
Changing Needles	6
• Changing needles	6
• To check for a good needle	6
Selecting Needle and Thread	6
Pattern Selection	7
Presser Foot Lifter	7
To Attach and Remove the Presser Foot	7
Reverse Stitch Lever	7
How to Drop the Feed Dog.....	7
Preparation of the Bobbin Thread	8
• Removing the bobbin	8
• Set the spool	8
• Winding the bobbin	9
• Inserting the bobbin	10
Threading the Machine	11
• To set the needle thread	11
• Using the needle threader	12
• Drawing up the bobbin thread	13

SECTION III BASIC SEWING

Straight Stitch Sewing	14
• Starting to sew	14
• Changing sewing direction	14
• Finishing sewing.....	14
• Using the seam guides on the needle plate	15
• Turning square corners	15
Triple Straight Stitch	15
Balancing Needle Thread Tension	16
• Choose the correct tension	16
• Tension is too tight	16
• Tension is too loose	16

SECTION IV UTILITY STITCHES

Zigzag Stitching.....	17
Overcasting	17
Tricot Stitch	17

SECTION V DECORATIVE STITCHING

Shell Tuck	18
Blind Stitch Hemming	18
Buttonhole	19
• Corded buttonhole	19
Embroidery	20

SECTION VI CARE OF YOUR MACHINE

Caution	21
• Cleaning the hook race and feed dogs	21
• Replacing the bobbin holder.....	22
• Replacing the Light Bulb	22
TROUBLESHOOTING	23

SECTION I NAME OF PARTS

Names of Parts

• How to attach the spool pin

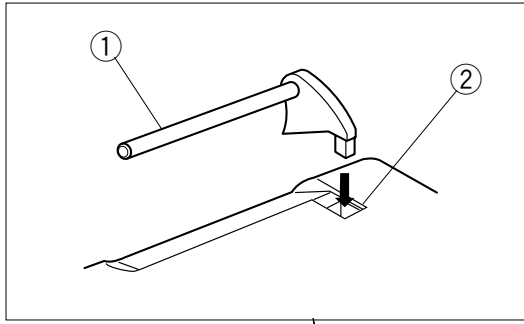

- ① Spool pin
- ② Setting hole
- * Insert the spool pin into the hole as shown.
(The spool pin is in the accessory bag.)

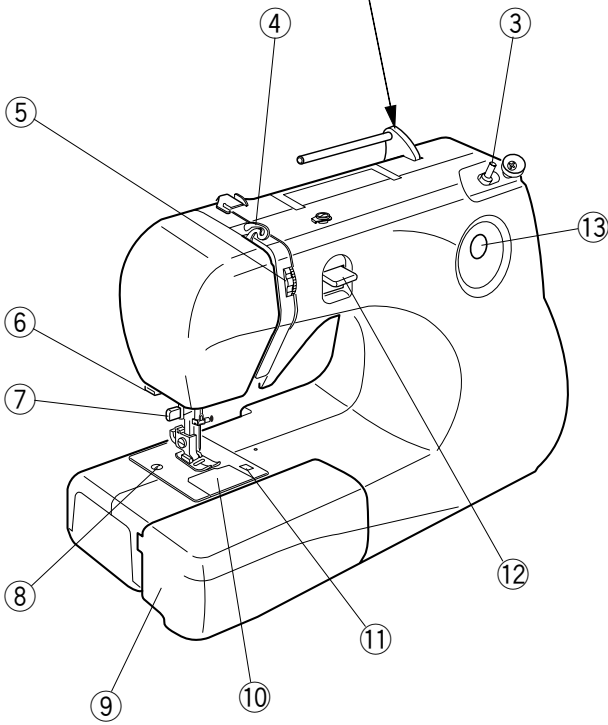

- ③ Bobbin winder spindle
- ④ Thread take-up lever
- ⑤ Thread tension dial
- ⑥ Thread cutter
- ⑦ Needle threader
- ⑧ Needle plate
- ⑨ Extension table (Accessory storage box)
- ⑩ Hook cover plate
- ⑪ Hook cover plate release button
- ⑫ Reverse stitch lever
- ⑬ Pattern indication window

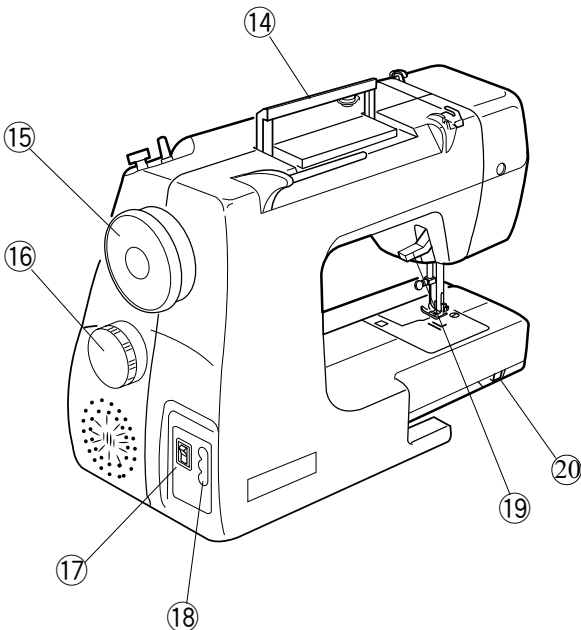

- ⑭ Carrying handle
- ⑮ Handwheel
- ⑯ Pattern selector dial
- ⑰ Power switch
- ⑱ Machine socket
- ⑲ Presser foot lifter
- ⑳ Drop feed dog lever

Standard Accessories and Storage Place

The following accessories are stored in the extension table.

- ① Bobbins
- ② Needles
- ③ Seam ripper
- ④ Screwdriver
- ⑤ Overedge foot
- ⑥ Buttonhole foot
- ⑦ Spool holder (large)
- ⑧ Spool holder (small)
- ⑨ Spool pin

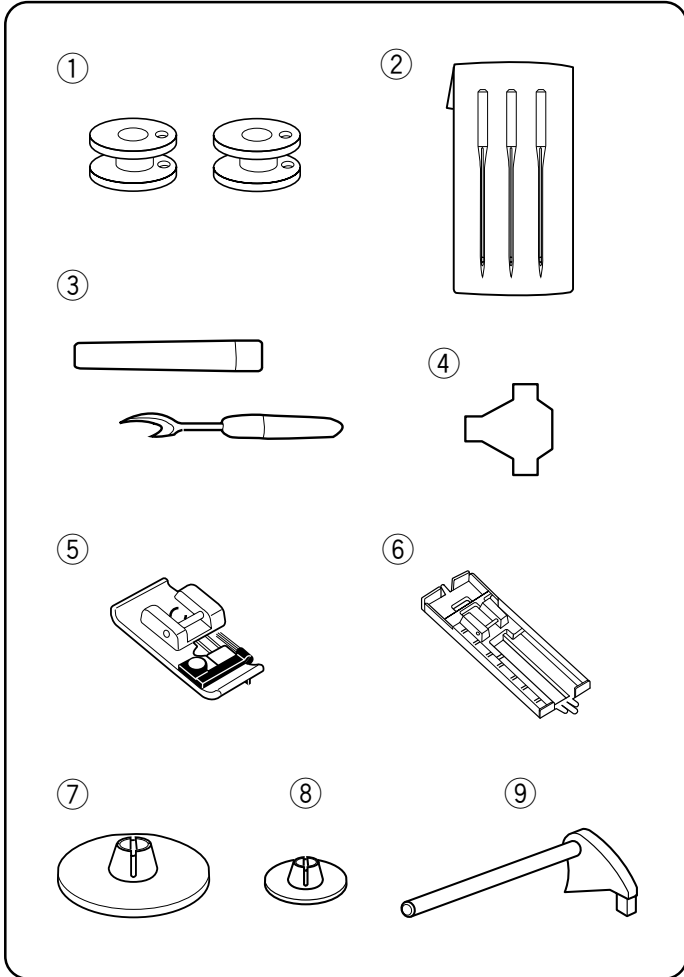

• Free arm

The extension table provides an extended sewing area and can be easily removed for free arm sewing.

Detaching the table:

Pull the table away from the machine, as illustrated.

Attaching the table:

Push the extension table until it snaps into the machine.

- ① Extension table
- ② Accessory storage box (for small parts)

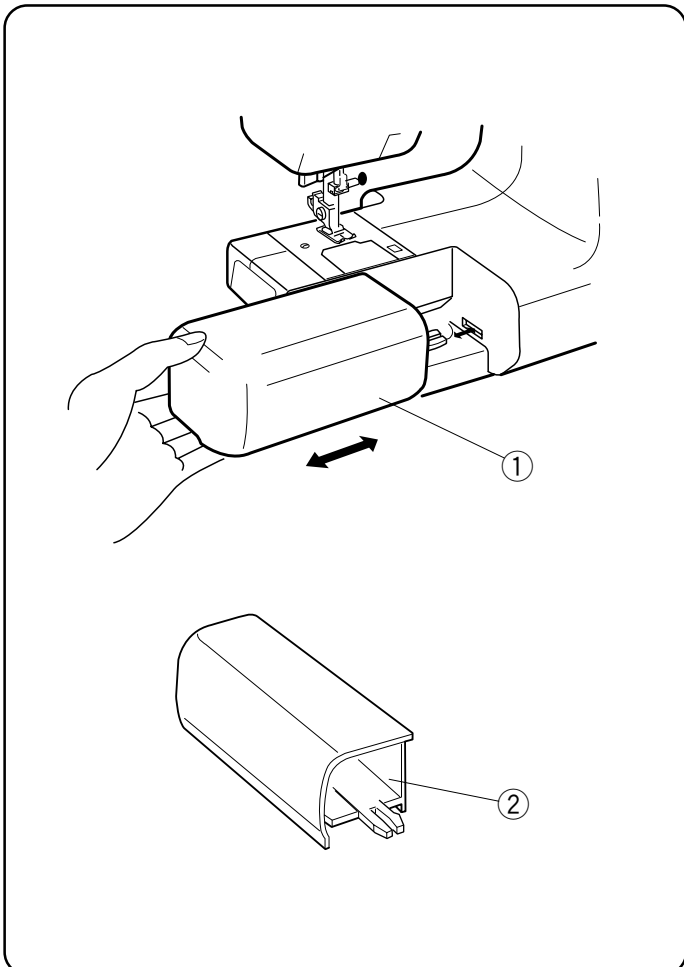

SECTION II GETTING READY TO SEW

Connecting Machine to Power Supply

Before connecting the power cord, make sure the voltage and frequency shown on the machine conform to your electrical power.

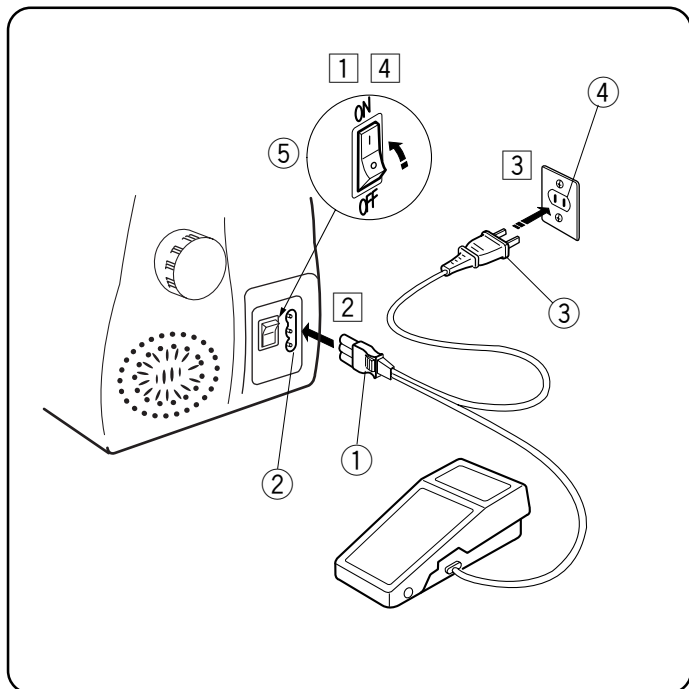

- ① Machine plug
- ② Machine socket
- ③ Power supply plug
- ④ Electrical outlet
- ⑤ Power switch

- 1 Turn off the power switch ⑤.
- 2 Insert the machine plug ① into the machine socket ② .
- 3 Insert the power supply plug ③ into the electrical outlet ④ .
- 4 Turn the power switch ⑤ to turn on the power and sewing light.

Controlling Sewing Speed

• Foot control

Sewing speed can be varied by the foot control. The harder you press on the control, the faster the machine runs.

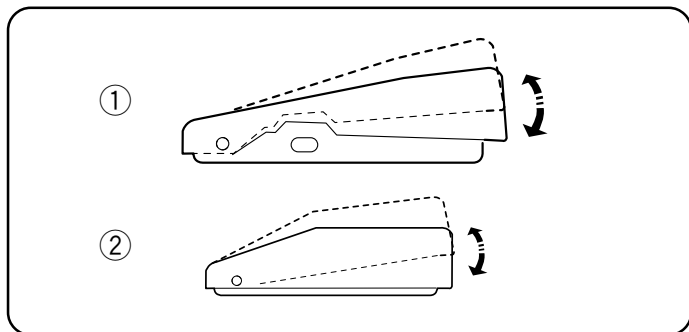

- ① Foot control for 120V
- ② Foot control for 240V

Operating Instructions:

Foot Controller Model YC-482J or TJC-150 is used with Sewing Machine Model 661.

This appliance has a polarized plug (one blade wider than the other). To reduce the risk of electric shock, this plug is intended to fit in a polarized outlet only one way. If the plug does not fit in the outlet, reverse the plug. If it still does not fit, contact a qualified electrician to install the proper outlet. Do not modify the plug in any way.

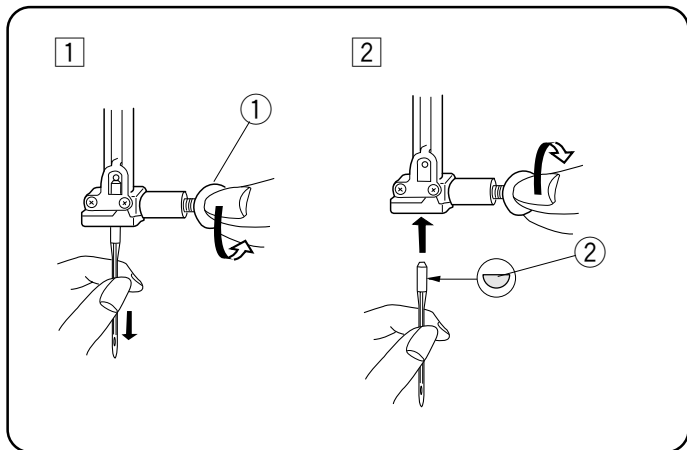

- ① Needle clamp screw
- ② Flat side of needle

Changing Needles

• Changing needles

- ① Turn off the power switch.
Raise the needle by turning the handwheel towards you and lower the presser foot. Loosen the needle clamp screw ① by turning it counterclockwise. Remove the needle from the clamp.
- ② Insert the new needle into the needle clamp with the flat side ② to the rear. When inserting the needle into the clamp, push it up as far as it will go. Tighten the clamp screw firmly by turning it clockwise.

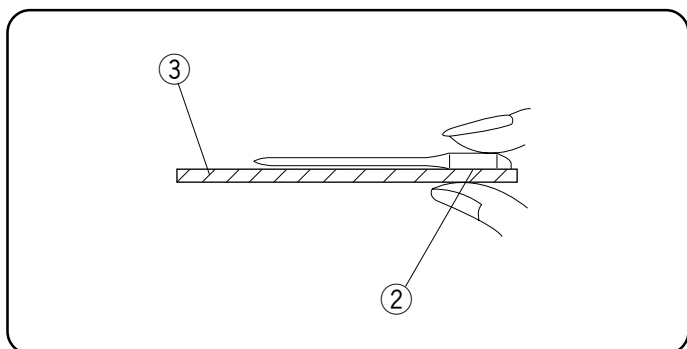

- ③ Flat surface

• To check for a good needle

Put the flat side of the needle onto something flat (needle plate, glass etc.).

The gap between the needle and the flat surface ③ should be consistent.

Never use a bent or blunt needle.

Note: Check your needles frequently for barbed or blunted points. A damaged needle can cause permanent snags or runs in knits, fine silks and silk-like-fabric.

Selecting Needle and Thread

FABRICS		THREADS	NEEDLE SIZE
LIGHT WEIGHT	Crepe de Chine, Voile, Lawn, Organdy, Georgette, Tricot	80 to 100 Fine Silk 80 to 100 Fine Cotton 80 to 100 Fine Polyester	9 or 11
MEDIUM WEIGHT	Linens, Cotton, Pique, Serge, Double Knits, Percale	50 Silk 60 to 80 Cotton 50 to 80 Synthetic Cotton-covered Polyester	11 or 14
		50 Cotton	14
HEAVY WEIGHT	Denim, Tweed, Gabardine, Coating, Drapery and Upholstery Fabric, Canvas	50 Silk 40 to 50 Cotton 40 to 50 Synthetic Cotton-covered Polyester	14 or 16
		30 Silk 30 Cotton	16

NOTE:

- * In general, fine threads and needles are used for sewing thin fabrics, and thicker threads and needles are used for sewing heavy fabrics.
- * Always test thread and needle size on a small piece of fabric which will be used for actual sewing.
- * Use the same thread for needle and bobbin.
- * When sewing stretch, very fine fabrics and synthetics, use a blue tipped needle.
- * The blue tipped needle effectively prevents skipped stitches.

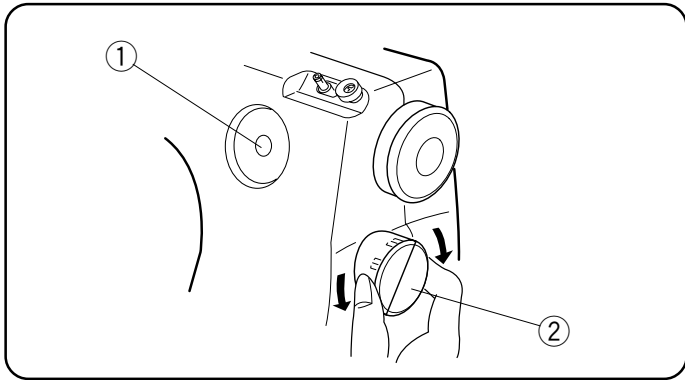

Pattern Selection

Raise the needle, turn the pattern selector dial to select the desired pattern.

Note: Do not turn the pattern selector dial while the needle is in the fabric, otherwise the needle may bend or break.

- ① Pattern indication window
- ② Pattern selector dial

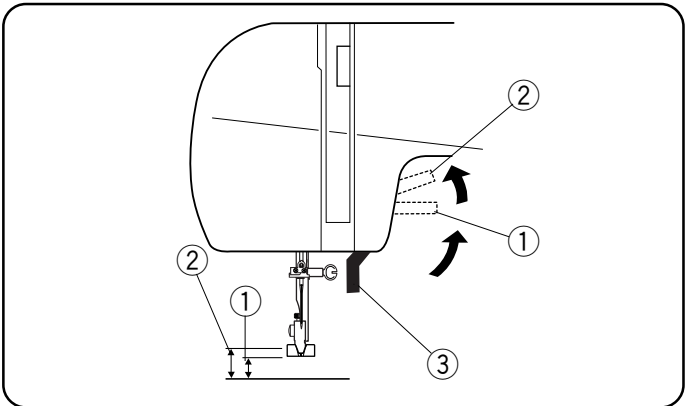

Presser Foot Lifter

The presser foot lifter raises and lowers the presser foot. You can raise it about 0.6 cm (1/4") higher than the normal up position for easy removal of the presser foot or to help you place heavy fabric under the foot.

- ① Normal up position
- ② High position
- ③ Presser foot lifter

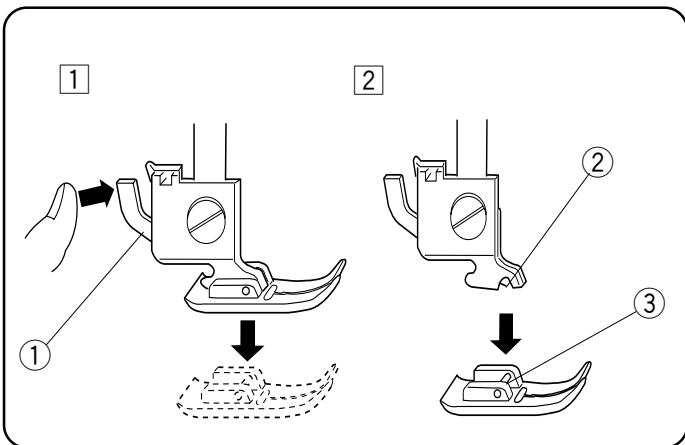

To Attach and Remove the Presser Foot

1 Raise the presser foot. Press the lever on the back of the foot holder.

The presser foot will drop off.

① Lever

2 Place the selected presser foot so the pin on the foot lies just under the groove of the foot holder.

Lower the presser bar to lock the foot in place.

② Groove

③ Pin

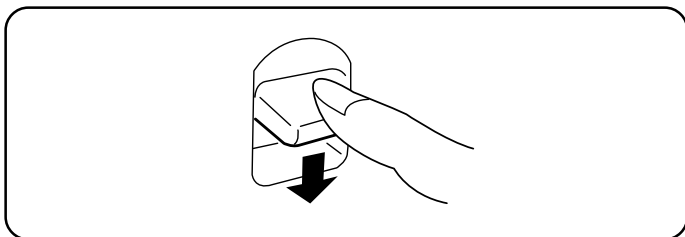

Reverse Stitch Lever

The machine will sew in reverse while the reverse stitch lever is depressed.

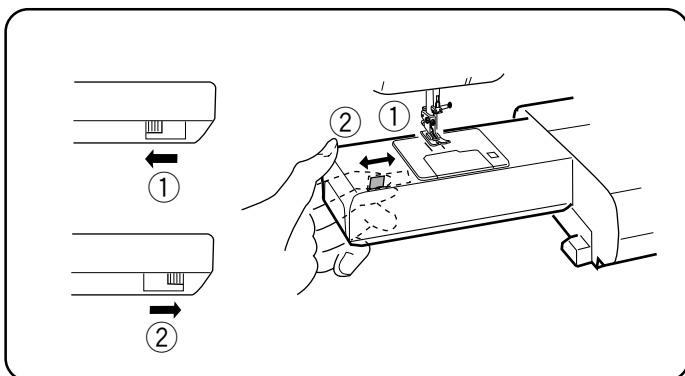

How to Drop the Feed Dog

The drop feed dog lever is located underneath the free arm bed on the back side of the machine.

To drop the feed dog, slide the drop feed dog lever to the right ①.

To raise the feed dog, slide the drop feed dog lever to the left ②, and turn the handwheel toward you.

The feed dog must be up for normal sewing.

Preparation of the Bobbin Thread

• Removing the bobbin

Gently slide the hook cover plate release button ① to the right and remove the cover plate ②.

Lift out the bobbin ③.

- ① Hook cover plate release button
- ② Hook cover plate
- ③ Bobbin

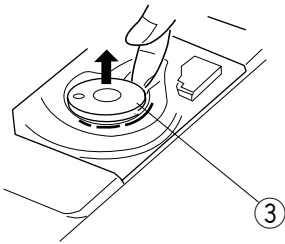
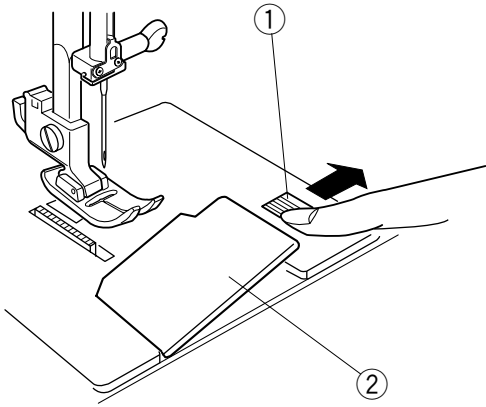

• Set the spool

Place the spool of thread on the spool pin with the thread coming off the spool as illustrated.

Press the large spool holder ① firmly against the spool of thread.

- ① Large spool holder
- ② End of thread

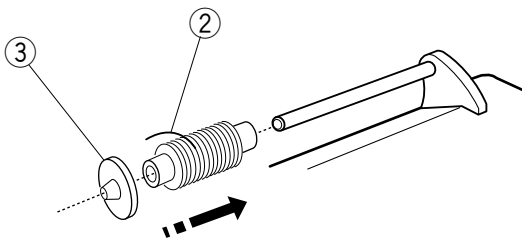
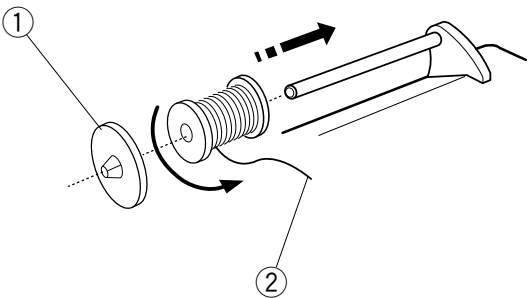

For small spool

- ③ Small spool holder

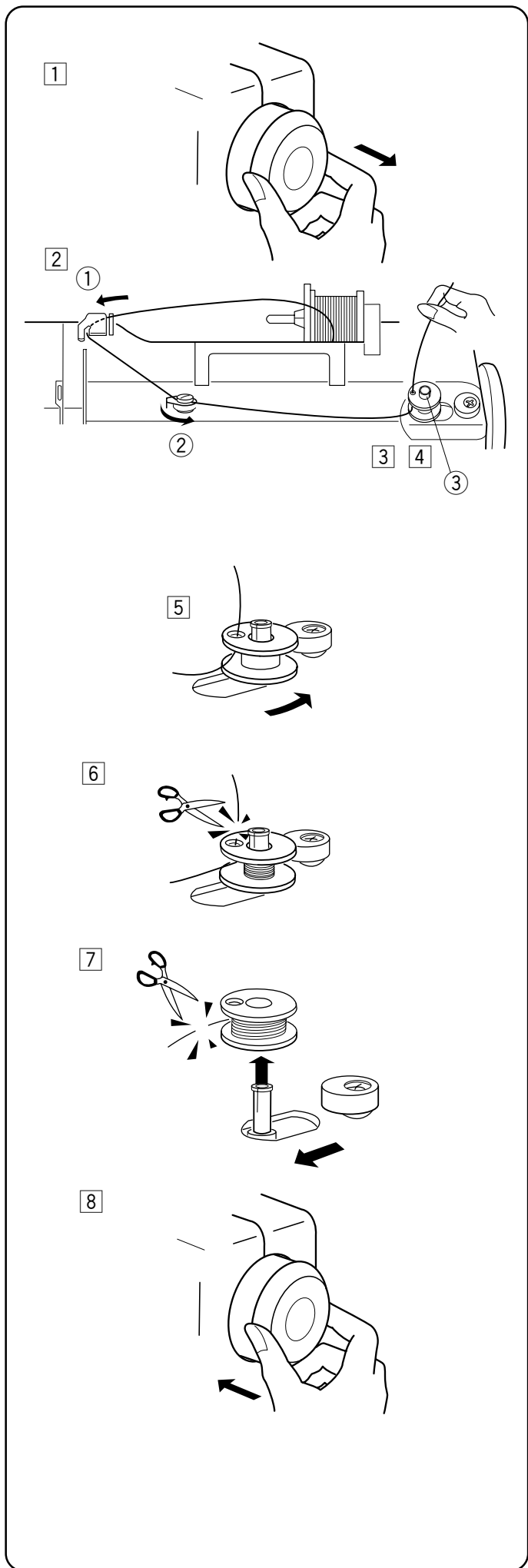

• Winding the bobbin

- 1 Pull the handwheel away from the machine to disengage the clutch.
- 2 Guide the thread around the thread guide ① and bobbin winder thread guide ② in order as illustrated.
 - ① Thread guide
 - ② Bobbin winder thread guide
- 3 Thread through the hole in the bobbin from the inside to the outside.
- 4 Put the bobbin on the bobbin winder spindle ③ with the free end of the thread coming out at the top.
 - ③ Bobbin winder spindle
- 5 Push the bobbin to the right.
- 6 With the free end of the thread held in your hand, depress the foot control. Stop the machine when the bobbin has made a few turns, and cut the thread close to the bobbin.
- 7 Depress the foot control again. When the bobbin is fully wound, it will stop automatically. Return the bobbin winder to its original position by moving the spindle to the left, and cut the thread as illustrated.
- 8 To engage the clutch, push the handwheel in.

• Inserting the bobbin

1 Place the bobbin ① in the bobbin holder ② with the thread running off as illustrated.

- ① Bobbin
- ② Bobbin holder
- ③ End of thread

2 Guide the thread into the notch (A) ④ on the front side of the bobbin holder. Draw the thread to the left, sliding it between the tension spring blades.

- ④ Notch (A)
- ⑤ Spring

3 Continue to draw the thread lightly until the thread slips into notch (B) ⑥. Pull out about 15 cm (6") of thread.

- ⑥ Notch (B)

4 Attach the hook cover plate ⑧. Check the threading by referring to the chart ⑨ shown on the hook cover plate ⑧.

- ⑦ Bobbin thread
- ⑧ Hook cover plate
- ⑨ Threading chart

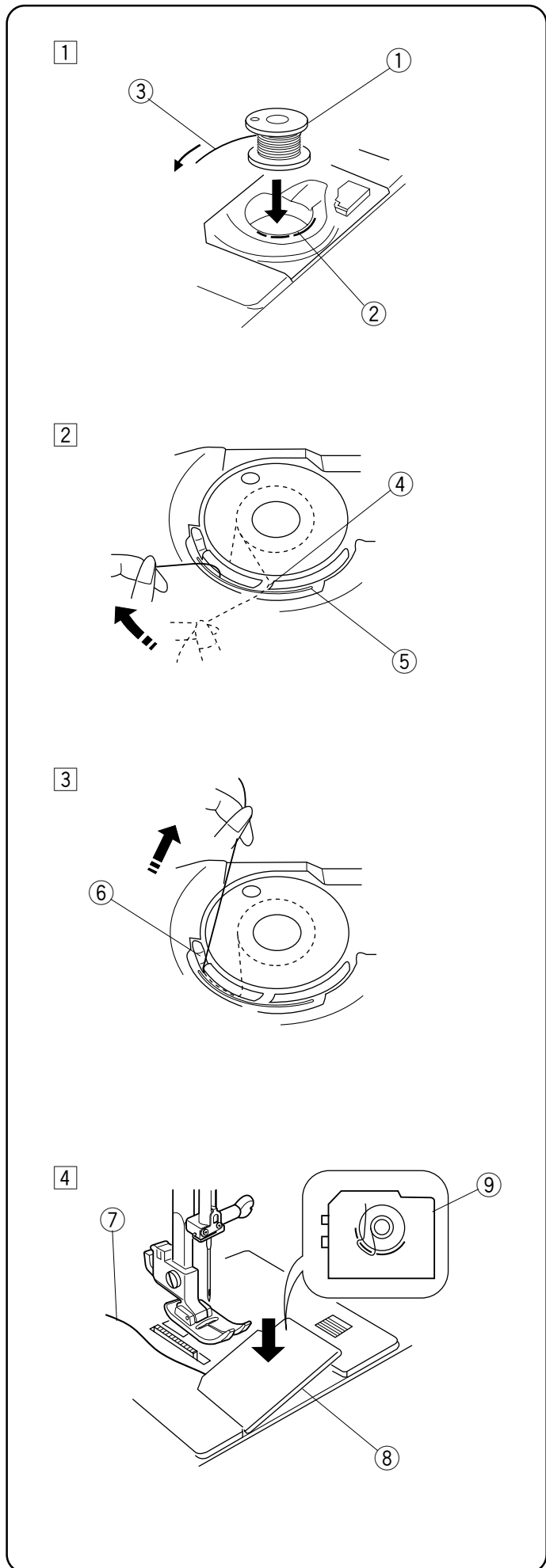

Threading the Machine

• To set the needle thread

- 1 Raise the presser foot with the presser foot lifter ①. Lead the thread from the spool and pass it through the thread guide ②. Then draw it down along the right slot.
 - ① Presser foot lifter
 - ② Thread guide
- 2 Then, down around the thread guide plate ③.
 - ③ Thread guide plate
- 3 Raise the take-up lever to its highest position by turning the handwheel towards you. Firmly draw the thread from right to left over the take-up lever ④ and down into the take-up lever eye.
 - ④ Thread take-up lever
- 4 Draw the thread down and slide the thread behind the needle bar thread guide ⑤ from the left.
 - ⑤ Needle bar thread guide
- 5 Use the needle threader to thread the needle.
 - ⑥ Needle
 (see page 12).

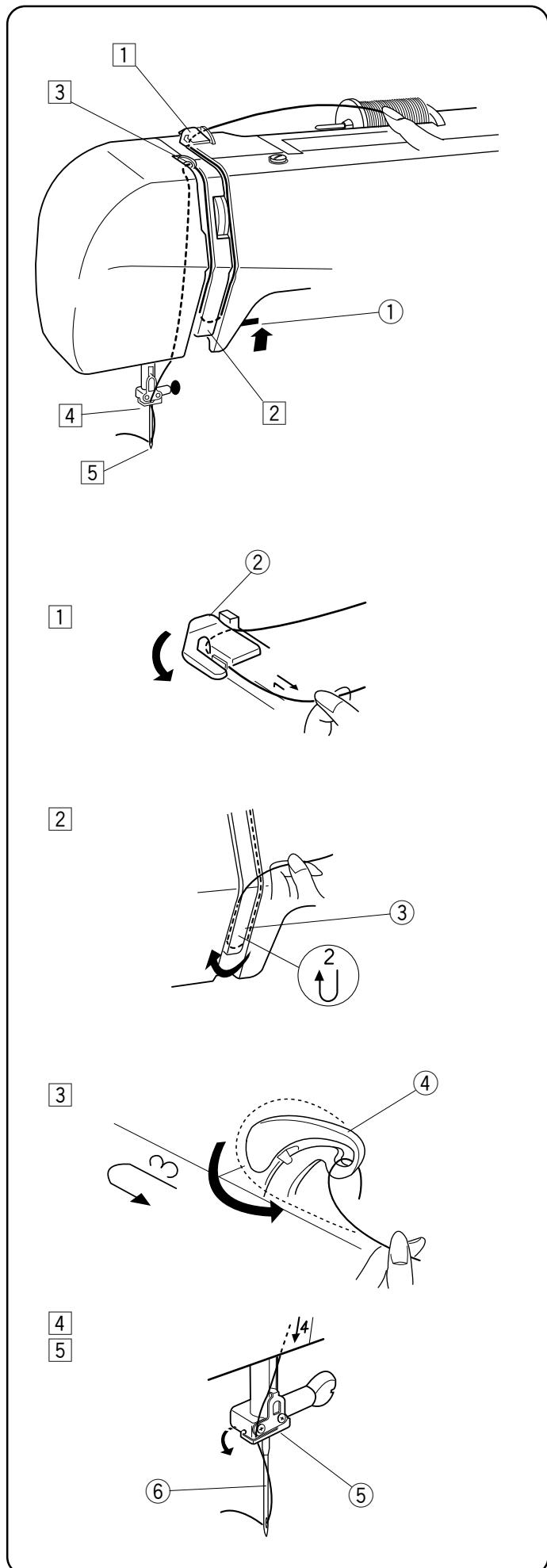

• Using the needle threader

1

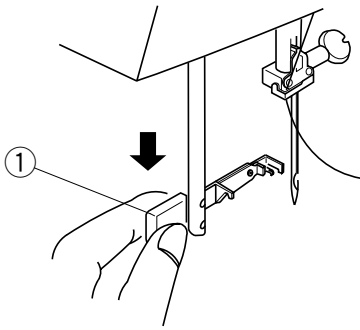

- 1 Turn the handwheel toward you to raise the needle to its highest position. Hold the needle threader knob ① and pull it down to its lowest position.

① Needle threader knob

2

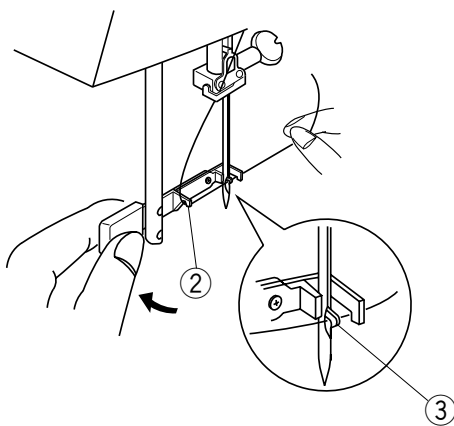

- 2 Push the needle threader knob ① to the back so that the hook ③ is coming out from the backside of the needle eye.

Hook the thread around the guide ② from the left. Pass the thread under the threader hook ③ and draw the thread to the right.

② Guide

③ Needle threader hook

3

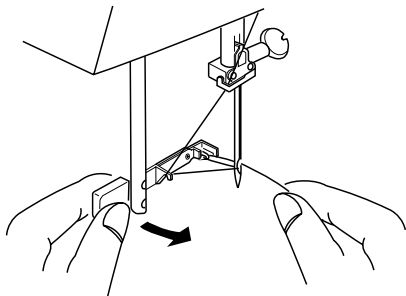

- 3 Push the needle threader knob ① towards you to pull out the needle thread as illustrated. Then push the knob ① up to pull the needle thread as illustrated.

4

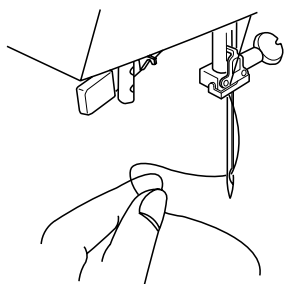

- 4 Pull the needle thread through the needle eye.

• Drawing up the bobbin thread

1

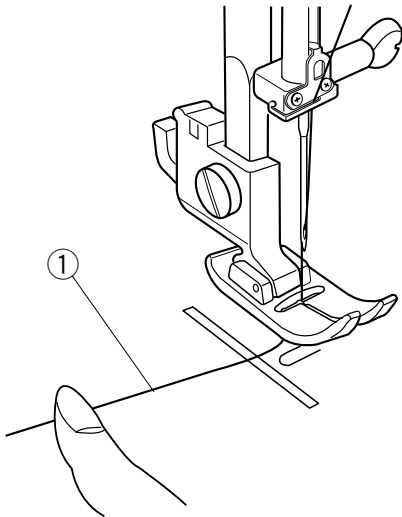

1 Raise the presser foot and hold the needle thread lightly with your left hand.

① Needle thread

2

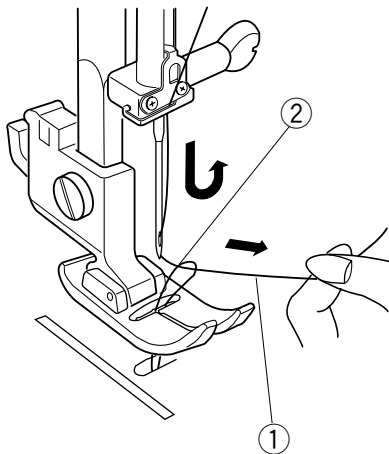

2 Turn the handwheel slowly towards you one complete turn.

Bring the bobbin thread up by pulling the needle thread as illustrated.

② Bobbin thread

3

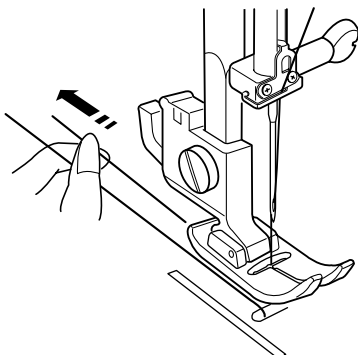

3 Pull 10 to 15 cm (4" to 6") of both threads back and under the presser foot.

SECTION III BASIC SEWING

Straight Stitch Sewing

Machine setting

- | | |
|------------------------|---|
| ① Stitch selector: |  |
| ② Presser foot: | Zigzag foot A |
| ③ Thread tension dial: | 2-6 |

Note: There are 3 types of stitch length selection.

• Starting to sew

Raise the presser foot and position the fabric with its edge next to a stitching guide line on the needle plate.

Lower the needle into the fabric.

Lower the presser foot and smooth the threads toward the back. Depress the foot control.

To fasten the beginning of the seam, press the reverse stitch lever and sew several reverse stitches.

Gently guide the fabric along the guide line letting the fabric feed naturally.

• Changing sewing direction

Stop the machine and turn the handwheel toward you to bring the needle down into the fabric.

Raise the presser foot.

Pivot the fabric around the needle to change the sewing direction as desired. Lower the presser foot and continue sewing.

• Finishing sewing

1. To fasten the end of the seam, press the reverse stitch lever and sew several reverse stitches ①.

① Reverse stitch lever

2. Raise the presser foot. Remove the fabric, draw the threads to the back.

3. Cut the threads using the thread cutter ②.

② Thread cutter

* The threads are cut the proper length for starting the next seam.

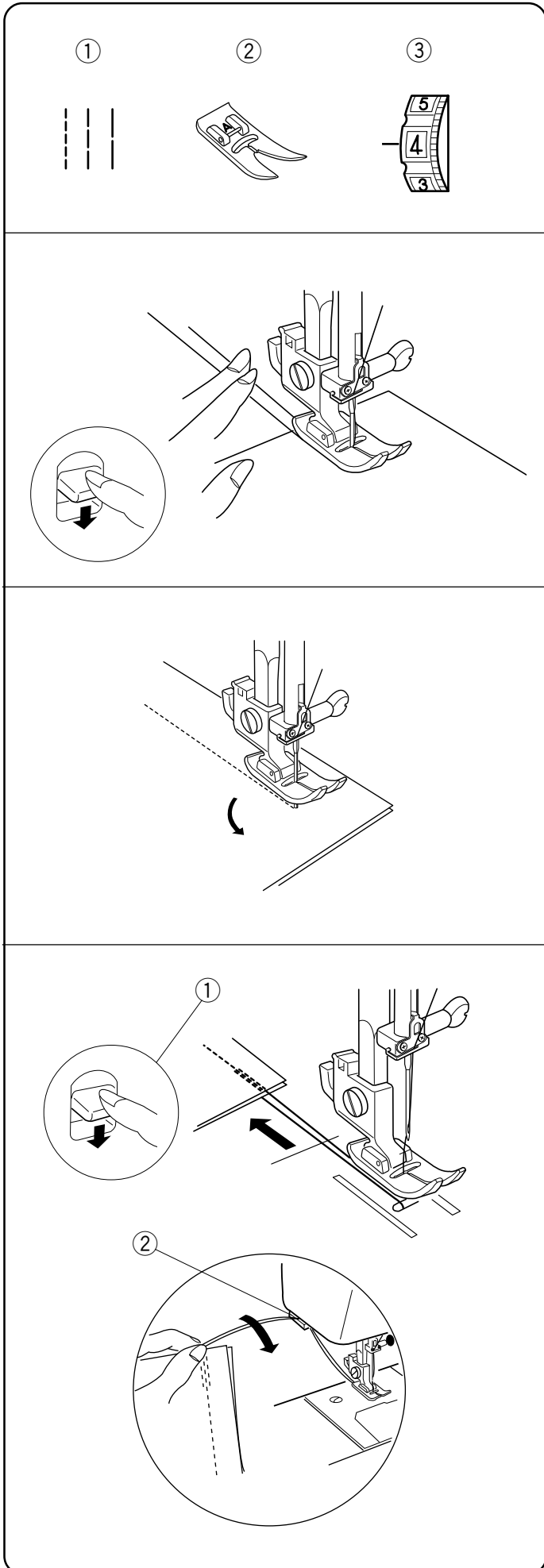

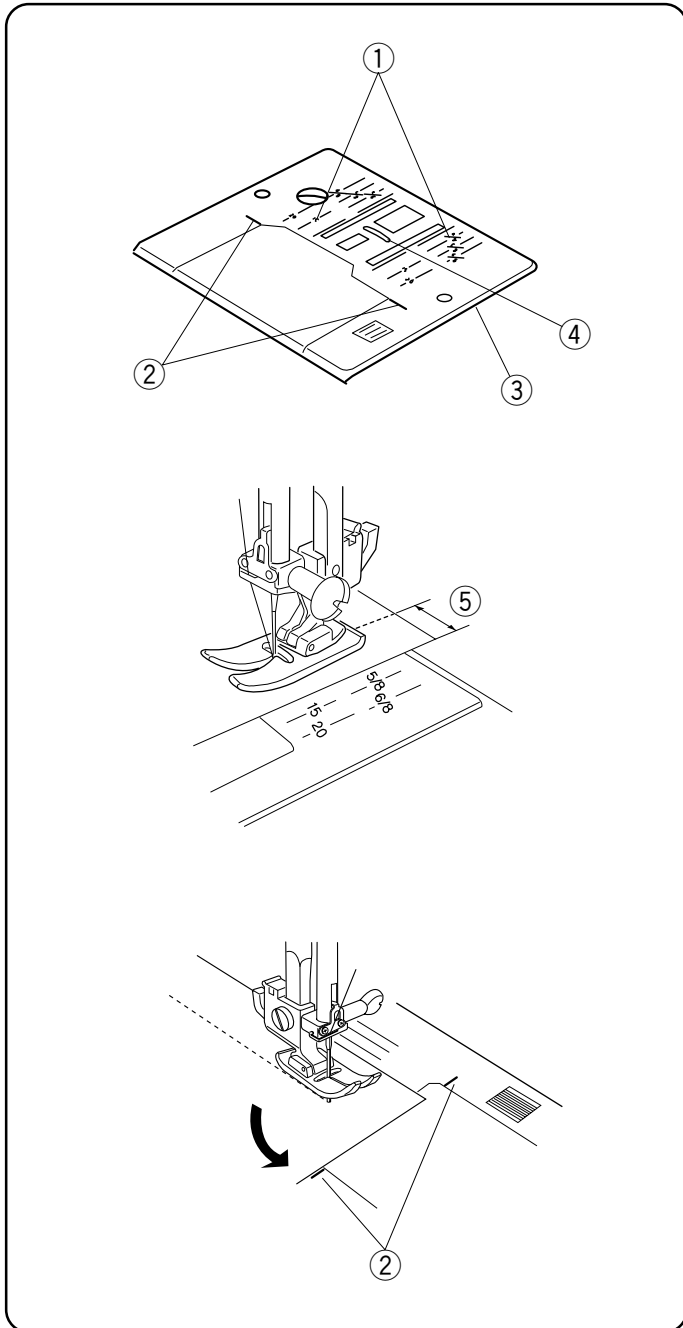

• Using the seam guides on the needle plate

The seam guides on the needle plate and hook cover plate help you to measure seam width.

* The numbers indicate the distance between the center needle position and the guide line.

Numbers on the needle plate	15	20	4/8"	5/8"	6/8"
Distance in centimeters	1.5	2.0	1.3	1.6	1.9

- ① Guide lines
- ② Cornering guide
- ③ Needle plate
- ④ Needle plate hole
- ⑤ Seam width from the center needle position

• Turning square corners

To turn a square corner 1.6 cm (5/8") from the fabric edge:

When the fabric edge facing you lines up with the cornering guide as illustrated, stop stitching and lower the needle by turning the handwheel towards you.

Raise the presser foot and turn the fabric to line the edge with the 1.6 cm (5/8") seam guide.

Lower the presser foot and begin stitching in the new direction.

- ② Cornering guides

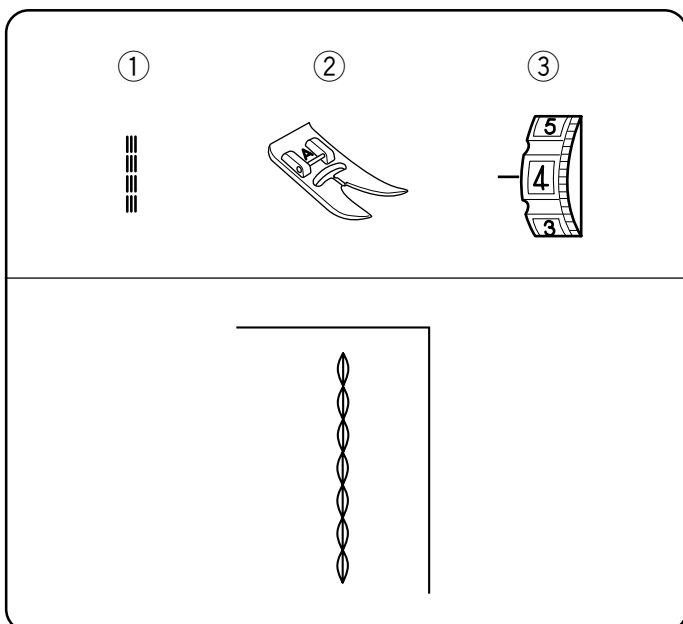

Triple Straight Stitch

Machine setting:

- ① Stitch selector: 
- ② Presser foot: Zigzag foot (A)
- ③ Thread tension dial: 2-6

* It is not necessary to adjust the stitch length.

This strong, durable pattern is recommended where both elasticity and strength are needed to insure comfort and durability. Use it to reinforce areas such as crotch and armhole seams. Also, use when constructing items such as backpacks for extra strength.

The pattern is sewn with two stitches forward and one stitch backward, forming a seam that does not rip easily. Garments should be basted for fitting before seaming.

Balancing Needle Thread Tension

• Choose the correct tension

For straight stitch:

The ideal straight stitch will have threads locked between the two layers of the fabric, as illustrated (magnified to show detail).

If you look at the top and bottom of the seam, you will notice that there are no gaps. Each stitch is smooth and even.

Turn the dial to alter the needle thread tension. The higher the number, the tighter the tension.

Results depend on:

- * stiffness and thickness of the fabric
- * number of fabric layers
- * type of stitch

- ① Needle thread (Top thread)
- ② Bobbin thread (Bottom thread)
- ③ Wrong side of fabric
- ④ Right side of fabric

• Tension is too tight

- ① The bobbin thread shows through on the right side of the fabric and it feels bumpy.

Turn the thread tension dial upwards (to a smaller number) to loosen the needle thread tension.

- ⑤ Thread tension dial

• Tension is too loose

- ② The needle thread shows through on the wrong side of the fabric and it feels bumpy.

Turn the thread tension dial downwards (to a larger number) to tighten the needle thread tension.

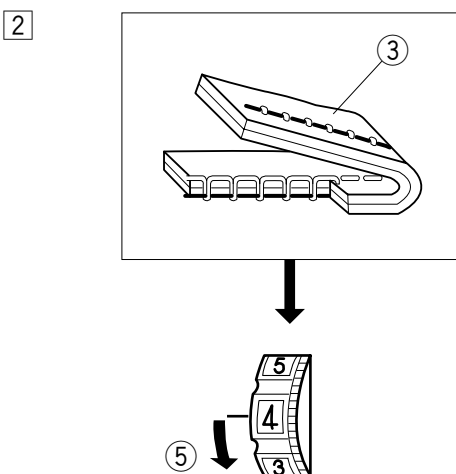
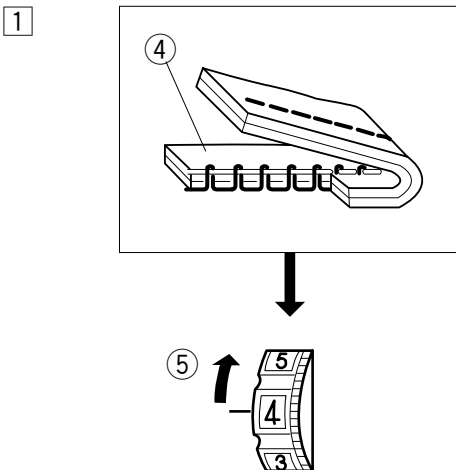
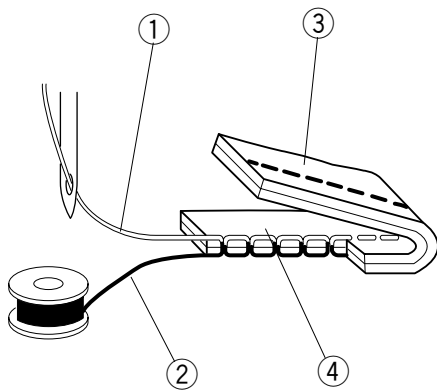

SECTION IV UTILITY STITCHES

Zigzag Stitching

Machine setting:

- ① Stitch selector: 
- ② Presser foot: Zigzag foot A
- ③ Thread tension dial: 2-5

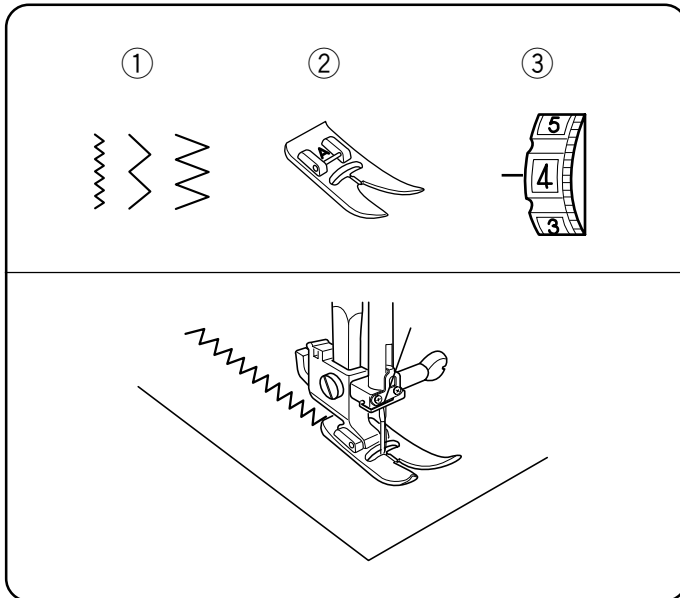

The zigzag stitch is one of the most versatile stitches on your machine. It can be a utility stitch for sewing on buttons, buttonholing, hemming, overcasting, mending and darning.

It can also be used to decorate with trims, appliques and cutwork or as a decorative stitch.



Overcasting

Machine setting:

- ① Stitch selector:  or 
- ② Presser foot: Overedge foot C
- ③ Thread tension dial: 3-6

Overcasting is used on the seam allowance to prevent fabrics from raveling at raw edges. It can be used to finish a hem edge. Place the edge of the fabric next to the black ridge of foot C.

- ④ Black ridge

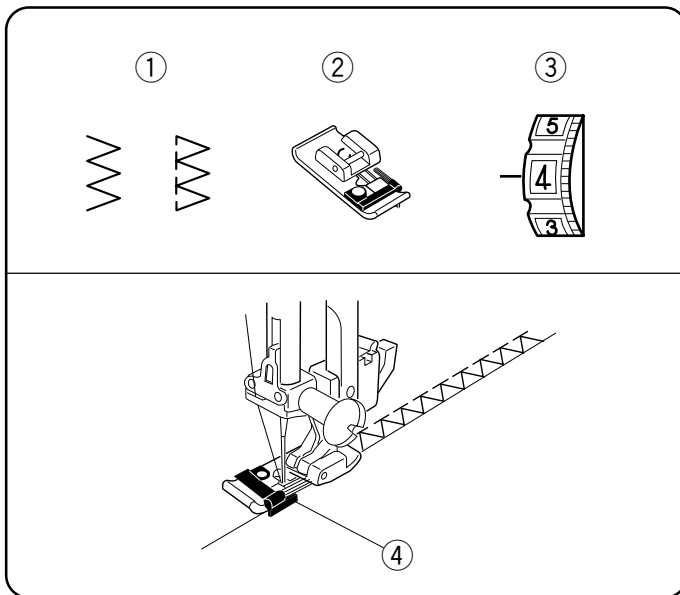

Tricot Stitch

Machine setting:

- ① Stitch selector: 
- ② Presser foot: Zigzag foot A
- ③ Thread tension dial: 3-6

This stitch is used to finish the seam allowance on synthetics and other fabrics that tend to pucker. The stitch is excellent for darning and mending tears. Place your fabric to allow a 1.6 cm (5/8") seam. Trim the extra seam allowance after sewing as illustrated.

Note: Be careful not to cut the stitches.

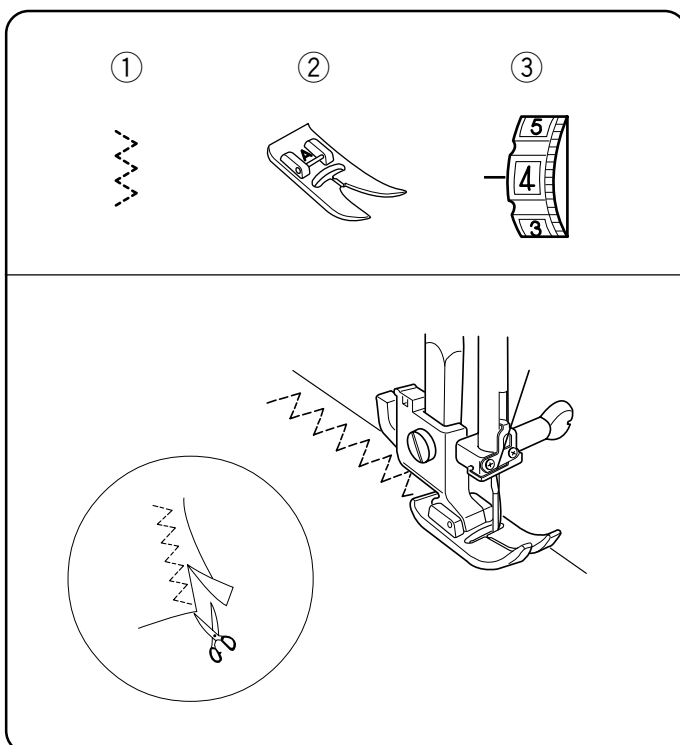

SECTION V DECORATIVE STITCHING

Shell Tuck

Machine setting:

- | | |
|------------------------|---|
| ① Stitch selector: |  |
| ② Presser foot: | Zigzag foot A |
| ③ Thread tension dial: | 6-8 |

Use a lightweight fabric (tricot, for example). Fold the fabric on the bias and stitch on the fold. Allow the needle to just clear the folded edge to create a shelled edge. You may need to increase the needle thread tension slightly.

If you sew rows of shell stitches, space the rows at least 5/8" (1.5 cm) apart. You can also sew shell stitches on knits or soft silky woven fabrics, in any direction.

- ① Fold and stitch on the bias.
- ② When the needle swings to the right, allow the needle to just clear the folded edge of the fabric when it zigzags. After stitching, open the fabric and iron to press the tucks flat to one side.

* If thread tension is too loose, tuck will not be formed. Therefore, increase the tension and set it between 6 to 8.

Blind Stitch Hemming

Machine setting:

- | | |
|------------------------|---|
| ① Stitch selector: |  |
| ② Presser foot: | Zigzag foot A |
| ③ Thread tension dial: | 1-4 |

How to fold the fabric

On heavyweight fabrics that ravel, the raw edge should be overcast first. Then fold the hem as illustrated.

- ① Wrong side of fabric
- ② 0.4-0.7 cm (1/4"-7/16")
- ③ Overcasting stitch

How to sew

- ① Position the fabric on the machine so that the needle just pierces the folded part of the fabric when the needle comes over to the extreme left side. Lower the presser foot. Sew, while guiding the fabric so that the needle catches the folded edge.

- ② If the needle drops on the left side too far, the stitches appear on the right side of the fabric.

- ④ Wrong side of fabric
- ⑤ Right side of fabric

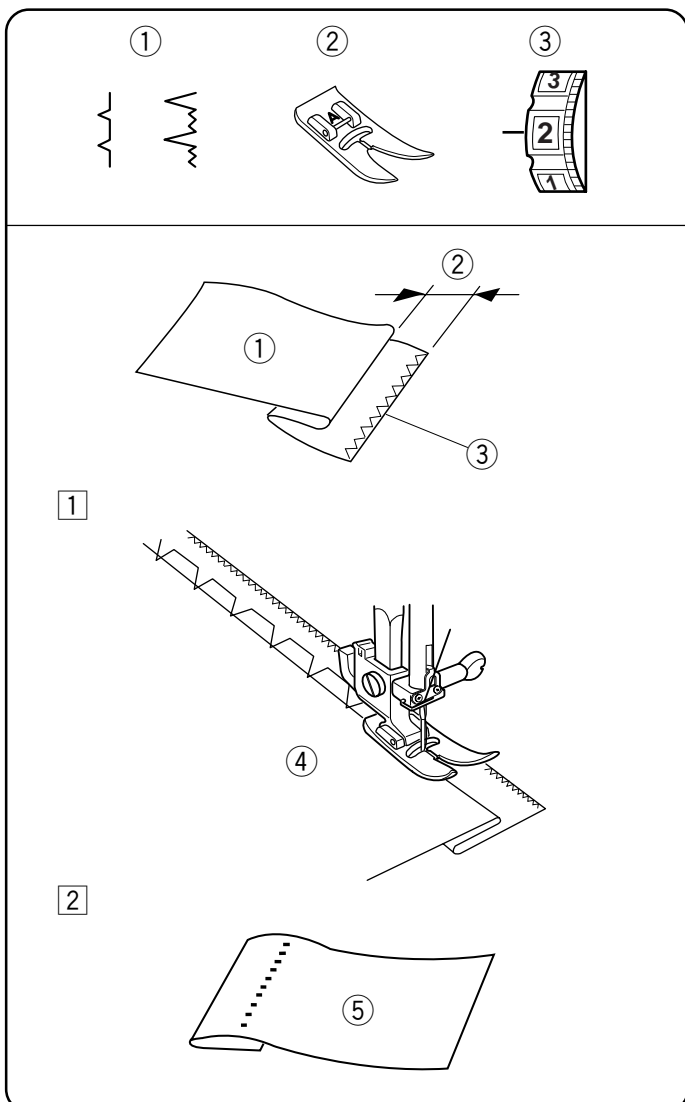
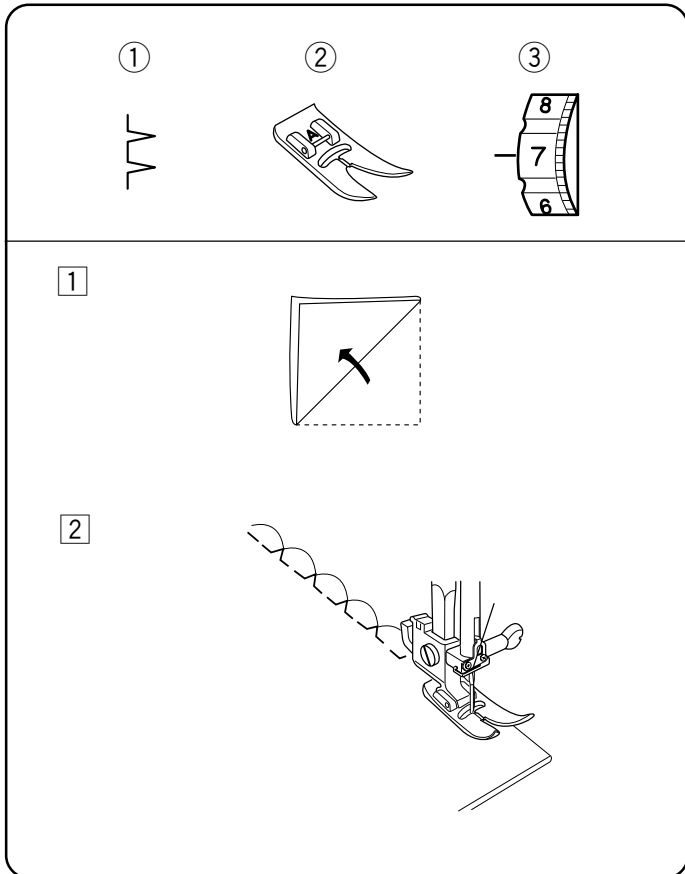

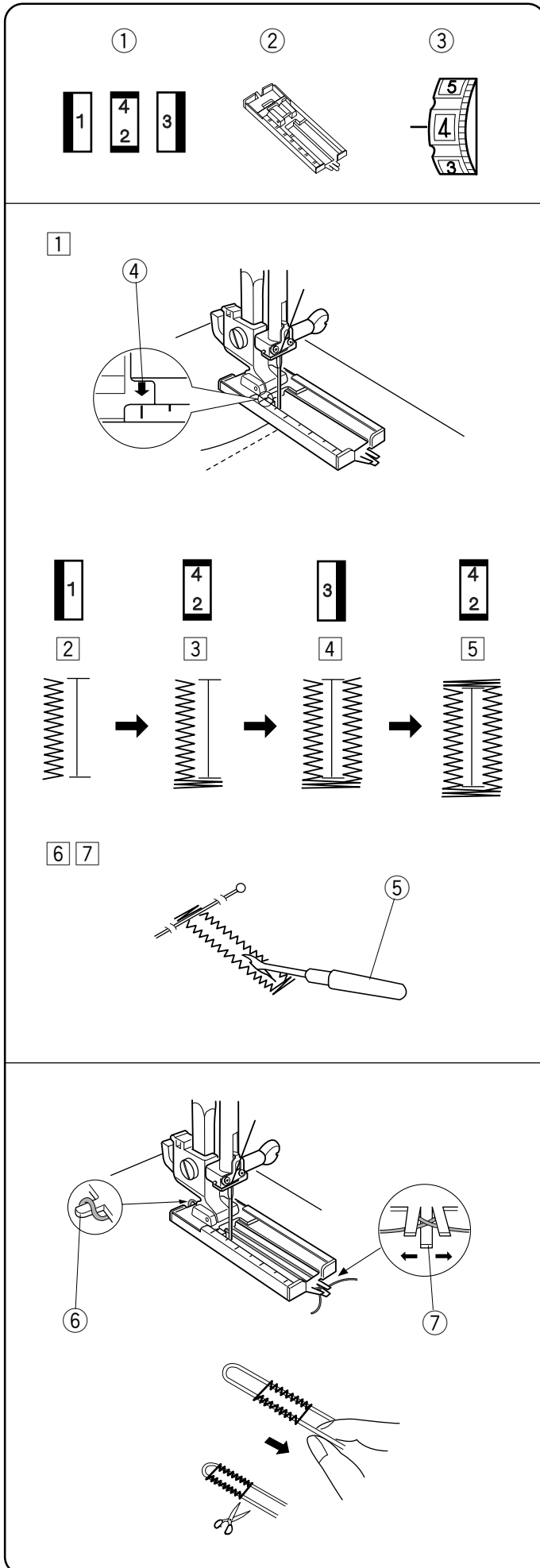





Buttonhole

Machine setting:

- ① Stitch selector: 
- ② Presser foot: Buttonhole foot
- ③ Thread tension dial: 1-5

* Before you sew the actual buttonholes on the actual garment, make several trial buttonholes on a fabric sample.

* Use interfacing on stretch fabrics.

- 1 Select BH 1(). Pull the slider so the top mark on the slider aligns with the start mark. Draw both threads to the left under the foot. Insert the garment under the foot.
 - ④ Start mark
- 2 Lower the needle at the starting point. Then lower the buttonhole foot. Sew the required length of the left side of the buttonhole and stop the machine.
 - 3 Raise the needle to its highest position by turning the handwheel, then select the BH 2,4(). Sew five bartack stitches and stop the machine.
 - 4 Raise the needle to its highest position and select BH 3(), sew the right side of buttonhole the same length as the left side and stop the machine.
 - 5 Raise the needle and select the BH 2,4(), and sew five bartack stitches.
 - 6 Raise the needle and presser foot. Remove the fabric from the machine. Cut both needle and bobbin threads leaving approximately 10 cm (4") of thread ends loose. Draw the needle thread to the wrong side of the fabric by pulling the bobbin thread. Then, knot the threads.
 - 7 Place a pin just before the bartack to prevent cutting bartack. Cut the opening with the seam ripper.
 - ⑤ Seam ripper

• Corded buttonhole

1. With the buttonhole foot raised, hook the filler cord on the spur ⑥ at the back of the buttonhole foot. Bring the ends toward you under the buttonhole foot, clearing the front end. Hook the filler cord into the forks ⑦ on the front of the buttonhole foot to hold them tight. Lower the needle into the garment where the buttonhole will start and lower the foot.
 - ⑥ Spur
 - ⑦ Forks
2. Depress the foot control and sew the buttonhole over the filler cord in the same way as described above.
3. Pull the left end of the filler cord to tighten it. Thread the end of the cord through a darning needle, draw it to the wrong side of the fabric and cut.

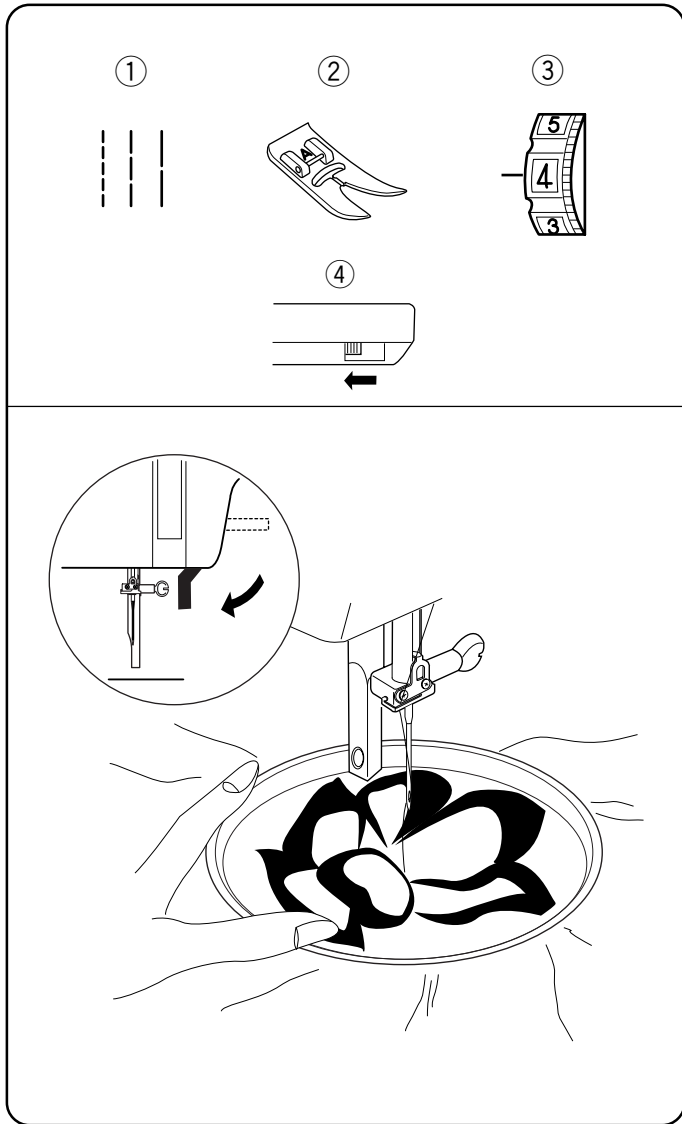

Embroidery

Machine setting

- | | |
|------------------------|---|
| ① Stitch selector: |  |
| ② Presser foot: | Remove |
| ③ Thread tension dial: | 2-6 |
| ④ Feed dogs | Dropped |

Note: There are 3 types of stitch length selection.

Drop the feed dogs and remove the foot holder.

Draw a design on the fabric with tailor's chalk.

Stretch the fabric between embroidery hoops, and place the hoops under the needle.

Lower the presser foot lifter to engage the needle thread tension. Holding the needle thread in your left hand, rotate the handwheel towards you one complete turn. Pull the needle thread to draw the bobbin thread to the right side of the fabric. At medium speed, stitch along the marked outline, guiding the fabric carefully by hand. After embroidery is completed, raise the feed dogs for normal sewing.

SECTION VI CARE OF YOUR MACHINE

Caution

Before performing cleaning or maintenance, make sure that the sewing machine is unplugged from the power source.

- * Turn the handwheel towards you to raise the needle before cleaning.
- * Do not dismantle the machine other than explained on this page.
- * Do not store the machine in a high-humidity area, near a heat radiator or in direct sunlight.
- * Clean the outside of the machine with a soft cloth and neutral soap.

• Cleaning the hook race and feed dogs

1 Remove the presser foot and needle. Remove screw ② on the left side of the needle plate ③ with the screwdriver ① supplied with the machine. Remove the needle plate and take out the bobbin.

- ① Screw driver
- ② Screw
- ③ Needle plate

2 Lift up the bobbin holder ④ and remove it.

- ④ Bobbin holder

3 Brush out dust and lint.

4 Clean the feed dogs ⑥ and hook race ⑦ with a small brush ⑤.

- ⑤ Brush
- ⑥ Feed dogs
- ⑦ Hook race

5 Wipe the hook race gently with a soft, dry cloth ⑧.

- ⑧ Dry cloth

* You may also use a vacuum cleaner.

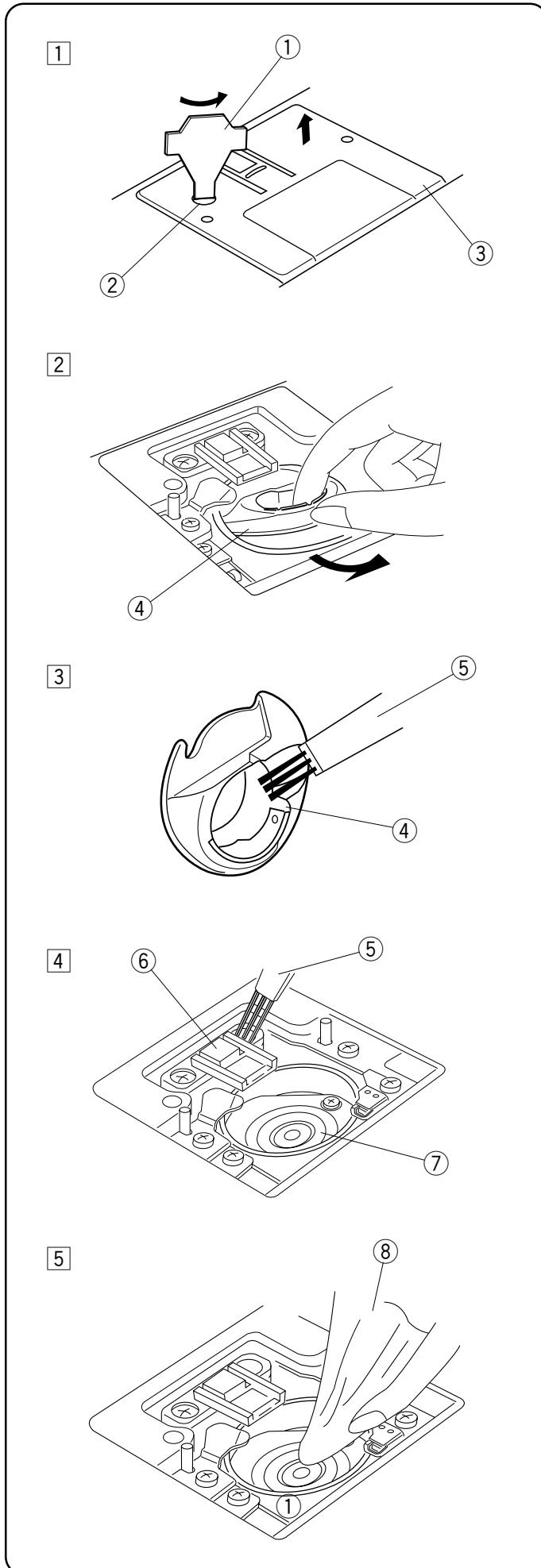

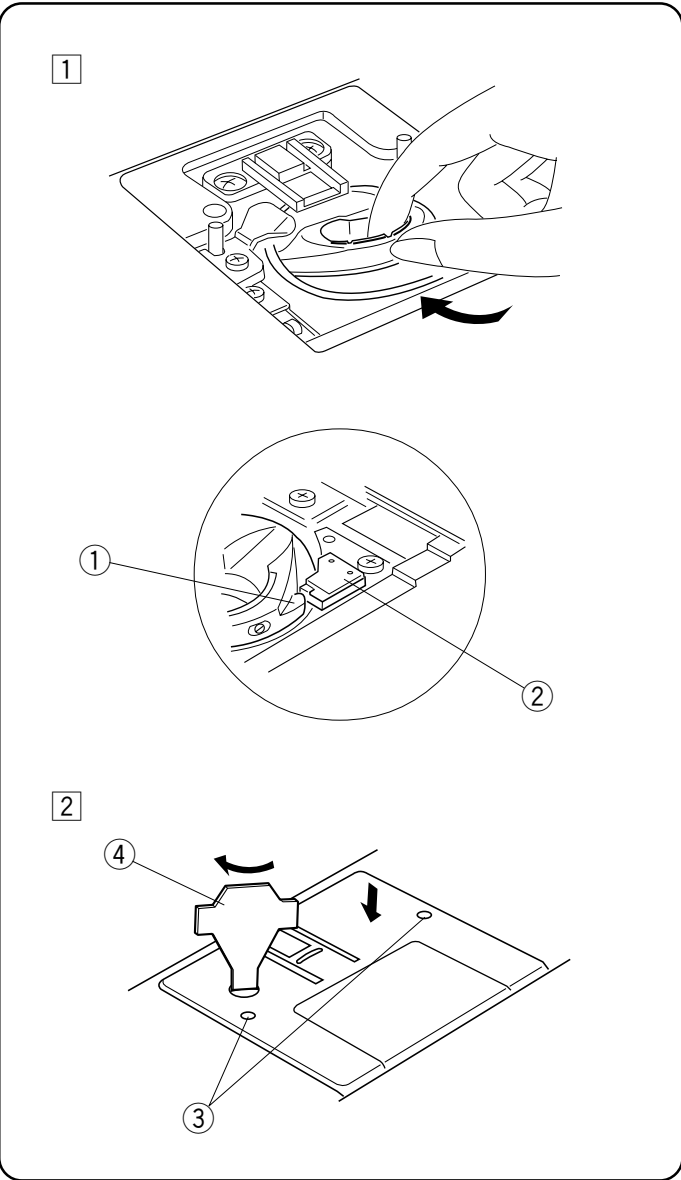

• Replacing the bobbin holder

- 1 Insert the bobbin holder so that the knob fits next to the stopper in the race.
Insert the bobbin.

- ① Knob
- ② Stopper

- 2 Replace the needle plate, inserting the two needle plate guide pins into the holes in the needle plate. Tighten the screw firmly with the screwdriver.

- ③ Guide holes
- ④ Screwdriver

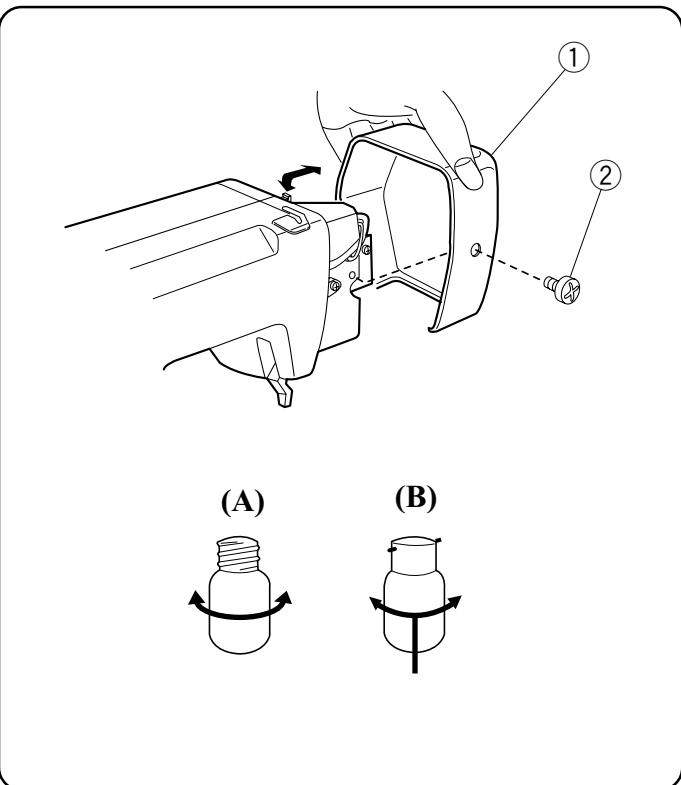

Replacing the Light Bulb

The sewing light is located behind the face plate.

Note: When replacing the bulb, unplug the machine.

Caution: Wait for the light bulb to cool down before touching it.

Loosen the screw and remove the face plate.

- ① Face plate
- ② Set screw

(A):

* To remove: Turn the bulb counterclockwise.

* To replace: Turn the bulb clockwise.

(B):

* To remove: Push and turn counterclockwise.

* To replace: Push and turn clockwise.

TROUBLESHOOTING

Condition	Cause	Reference
The needle thread breaks.	<ol style="list-style-type: none"> 1. The needle thread is not threaded properly. 2. The needle thread tension is too tight. 3. The needle is bent or blunt. 4. The needle is incorrectly inserted. 5. The needle thread and the bobbin thread are not set properly under (drawn to the rear of) the presser foot when sewing is started. 6. The thread is too heavy or too fine for the needle. 	<p>Refer to page 11 Refer to page 16 Refer to page 6 Refer to page 6</p> <p>Refer to page 13,14 Refer to page 6</p>
The bobbin thread breaks.	<ol style="list-style-type: none"> 1. The bobbin thread is not threaded properly in the bobbin holder. 2. Lint has collected in the bobbin holder. 3. The bobbin is damaged and does not turn smoothly. 	<p>Refer to page 10 Refer to page 21 Change the bobbin.</p>
The needle breaks.	<ol style="list-style-type: none"> 1. The needle is incorrectly inserted. 2. The needle clamp screw is too loose. 3. The pattern selector dial has been turned while the needle was in the material. 4. The needle is too fine for the fabric being sewn. 	<p>Refer to page 6 Refer to page 6</p> <p>Refer to page 7 Refer to page 6</p>
Skipped stitches	<ol style="list-style-type: none"> 1. The needle is incorrectly inserted. 2. The needle is bent or blunt. 3. The needle and /or threads are not suitable for the work being sewn. 4. A blue tip needle is not being used for sewing stretch, very fine fabrics or synthetics. 5. The needle thread is not threaded properly. 	<p>Refer to page 6 Refer to page 6</p> <p>Refer to page 6</p> <p>Refer to page 6 Refer to page 11</p>
Seam puckering	<ol style="list-style-type: none"> 1. The needle thread tension is too tight. 2. The needle thread is not threaded properly. 3. The needle thread is too heavy for the fabric being sewn. 	<p>Refer to page 16 Refer to page 11 Refer to page 6</p>
Machine doesn't run	<ol style="list-style-type: none"> 1. The machine plug is not connected properly. 2. Lint has built up in the bobbin holder or hook race. 3. The bobbin winder spindle is still in the winding position. 	<p>Refer to page 5 Refer to page 21 Refer to page 9</p>

JANOME

INSTRUCTION BOOK

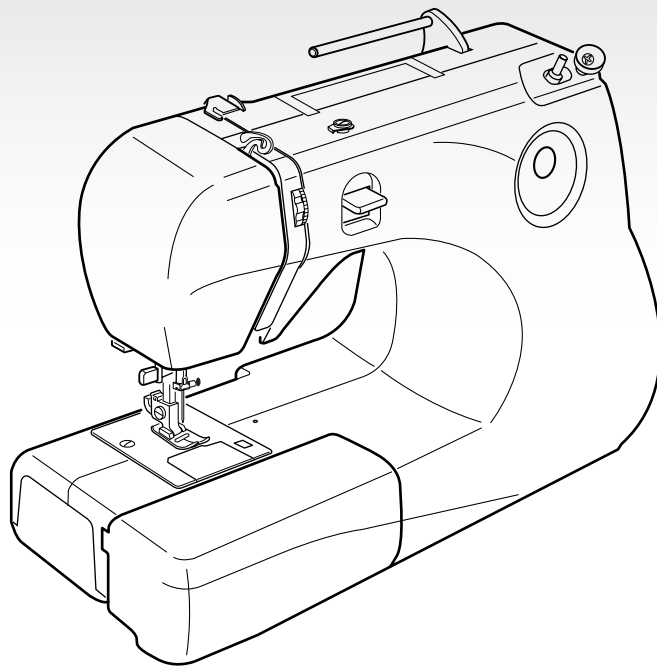

Jem Gold 2

MODEL 661

